

Compensator SAE 1" to 5"



Rubber compensators are elastic connectors with turnable SAE flanges. Compensators are used for damping oscillations, vibrations, noises and movements in axial and transversal direction.

Design

Rubber compensators have a plain surface vulcanized to a fabric body (inside and outside) of the rubber part. The outside is weather resistant and protects the fabric against ageing, wear and corrosion. The interior of the rubber part consists of nitril-butadien-caoutchouc (NBR). The outer layer is made of CR (chloroprene rubber). Because compensators have tightening lips on both sides, further seals are not necessary.

Use

For all mineral oil products, crude oil, lubrication oil, cooling oil (-20°C up to 80°C), grease, cold water, warm water up to 60°C, water/oil emulsions, fuel with 30% aromatic content. For operation in suction and return lines.

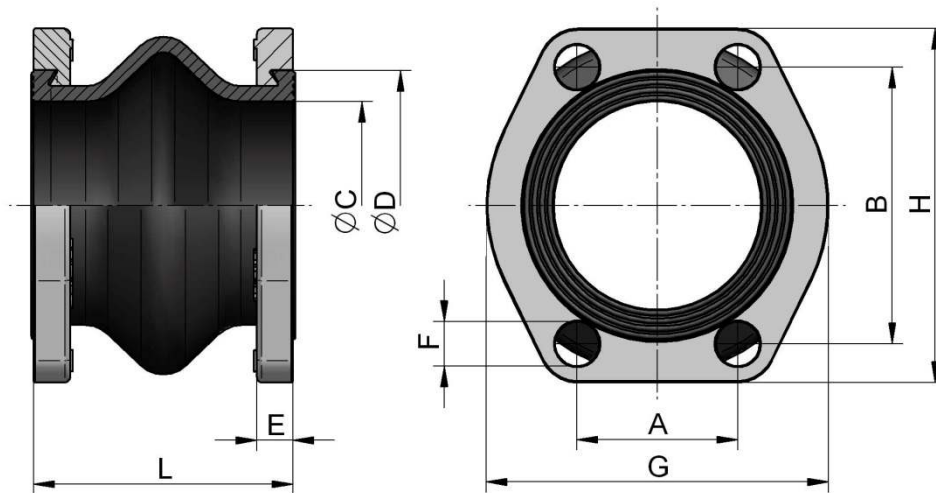

order number	description	size		A	B	D	C	E	F	G	H	L	weight
		SAE	NG*	[mm]	[mm]	[mm]	[mm]	[mm]	[mm]	[mm]	[mm]	[mm]	[kg]
SDKSS025	K16S – 25	1"	25	26,2	52,4	43	25 ⁺¹ ₋₃	11	11	59	70	65	0,4
SDKSS032	K16S – 32	1 ¼"	32	30,2	58,7	50	32 ⁺¹ ₋₃	11	13	73	81	65	0,5
SDKSS040	K16S – 40	1 ½"	40	35,7	70,0	62	40 ⁺¹ ₋₃	13	13	83	95	100	0,8
SDKSS050	K16S – 50	2"	50	42,9	77,8	72	48 ⁺¹ ₋₃	13	13	97	103	100	1,0
SDKSS063	K16S – 63	2 ½"	63	50,8	89,0	87	63 ⁺¹ ₋₃	14	13	109	115	100	1,2
SDKSS080	K16S – 80	3"	80	62,0	106,4	104	80 ⁺¹ ₋₃	14	17	131	136	100	1,8
SDKSS092	K16S – 92	3 ½"	90	70,0	120,7	120	90 ⁺¹ ₋₃	14	17	140	152	100	1,9
SDKSS100	K16S – 100	4"	100	77,8	130,2	130	100 ⁺¹ ₋₃	16	17	152	162	100	2,5
SDKSS126	K16S – 125	5"	125	92,0	152,4	155	125 ⁺¹ ₋₃	16	17	165	184	130	3,0

*... NG = nominal size

Material

inside	NBR 70 shore ± 5
outside	CR
flange	steel



Working Pressure

maximum working pressure	1,5 bar (absolute)
--------------------------	--------------------

Please read manual before installation and for the maximum movement tolerances of the rubber connection! Note, that the dimension tolerances have to be taken from the corresponding scale drawing.